

C. H. REID.
HAT FINISHING LATHE.

No. 421,514.

Patented Feb. 18, 1890.

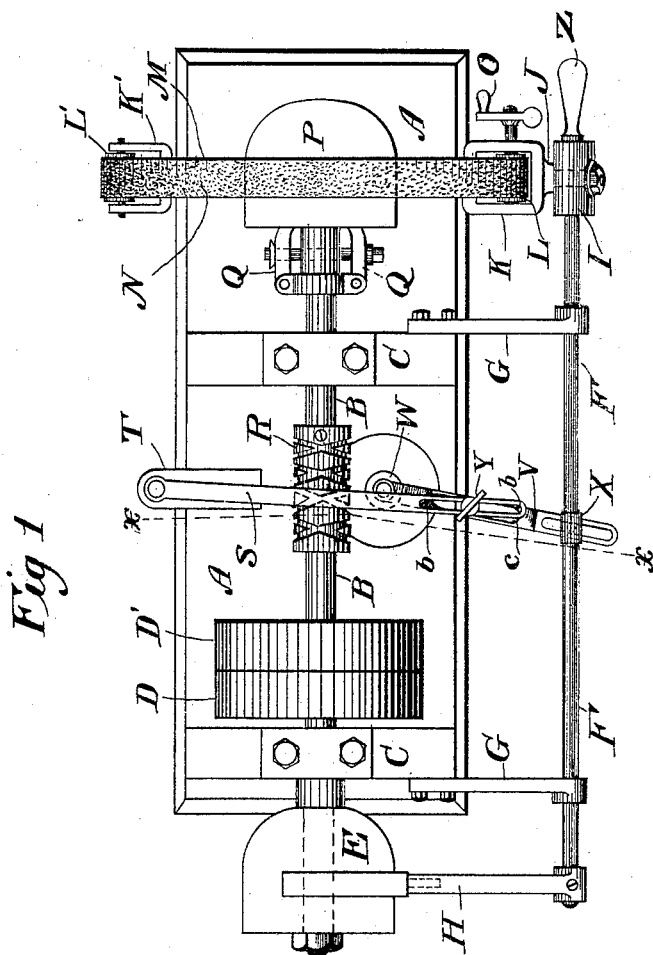

Fig 1

Witnesses
S. Williamson.
F. W. Gilhuley.

Inventor
Charles H. Reid
By J. M. Smith.

attg.

(No Model.)

3 Sheets—Sheet 2.

C. H. REID.
HAT FINISHING LATHE.

No. 421,514.

Patented Feb. 18, 1890.

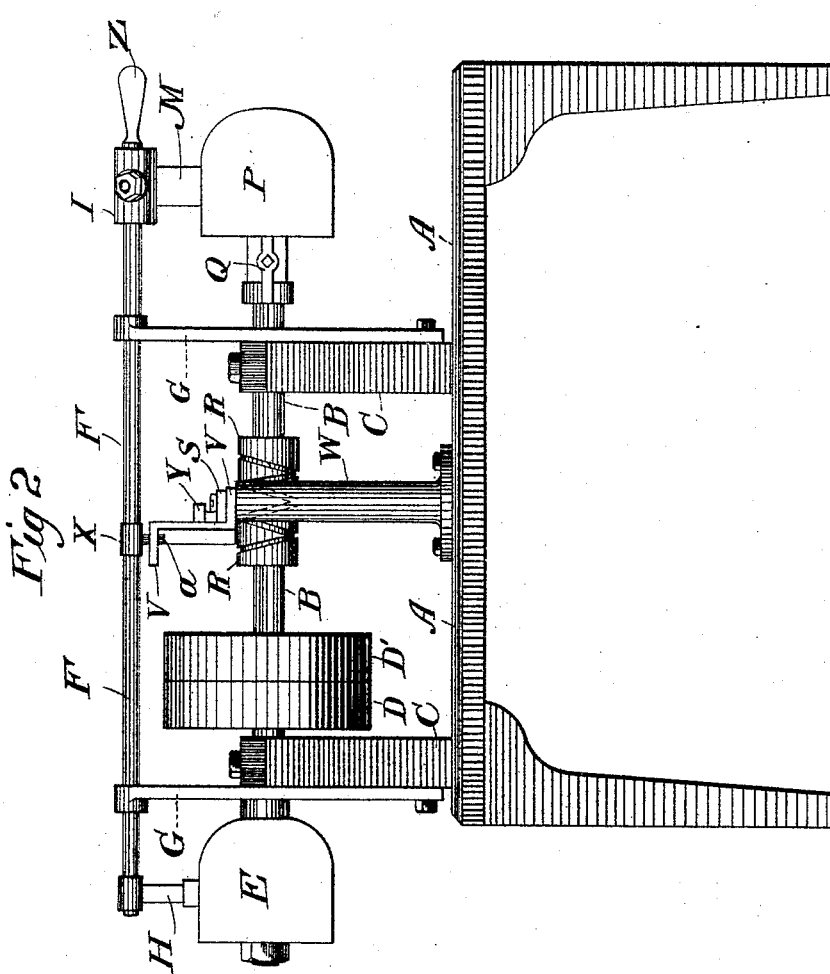

Witnesses
S. Williamson.
F. W. Gilhuley.

Inventor
Charles H. Reid.
By
J. M. Smith
Att'y.

(No Model.)

3 Sheets—Sheet 3.

C. H. REID.
HAT FINISHING LATHE.

No. 421,514.

Patented Feb. 18, 1890.

Fig 3

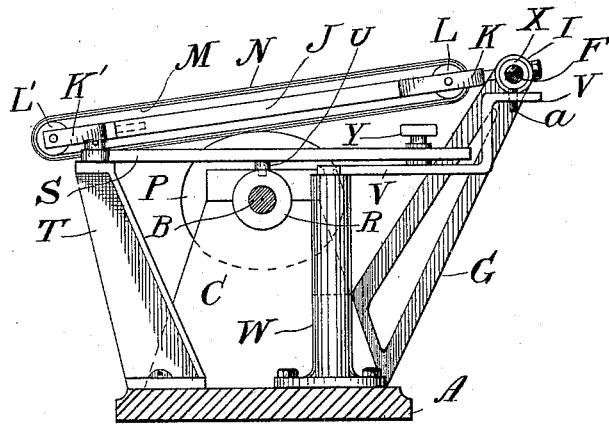

Witnesses

S. Williamson.

F. W. Gilhuley.

Inventor

Charles H. Reid

By

J. M. Smith.

att'y.

UNITED STATES PATENT OFFICE.

CHARLES H. REID, OF DANBURY, CONNECTICUT.

HAT-FINISHING LATHE.

SPECIFICATION forming part of Letters Patent No. 421,514, dated February 18, 1890.

Application filed June 5, 1889. Serial No. 313,206. (No model.)

To all whom it may concern:

Be it known that I, CHARLES H. REID, a citizen of the United States, residing at Danbury, in the county of Fairfield and State of Connecticut, have invented certain new and useful Improvements in Hat - Finishing Lathes; and I do hereby declare the following to be a full, clear, and exact description of the invention, such as will enable others skilled in the art to which it appertains to make and use the same.

My invention relates to certain new and useful improvements in hat-finishing lathes, and has for its object to improve on the construction shown and described in Letters Patent No. 301,279, granted to me on the 1st day of July, 1884, and to render the movements of the sandpapering mechanism in such machine universal and entirely automatic.

With these ends in view my invention consists in the details of construction and combination of elements hereinafter set forth, and then specifically designated by the claims.

In order that those skilled in the art to which my invention appertains may fully understand how to make and use the same, I will proceed to describe its construction and operation in detail, referring by letter to the accompanying drawings, forming a part of this specification, in which—

Figure 1 is a plan view of my present improvement; Fig. 2, a side elevation of the same, and Fig. 3 a section at the line $x x$ of Fig. 1.

Similar letters denote like parts in the several figures of the drawings.

In this present application I will refer incidentally to the chuck which supports the hat-block, since I am enabled to use any means for attaching the block to the power-shaft; and, in fact, it is not necessary to use a chuck at all, for said block may be secured directly to said shaft by bolts or nuts in any ordinary or well-known manner.

A is the bed-plate of my improved lathe; B, the power-shaft, mounted within uprights C, which project from said bed-plate; and D D', loose and tight pulleys, respectively, mounted on said shaft and adapted in the ordinary and well-known manner to control the movements of said shaft.

E is a templet rigidly mounted upon the

shaft and corresponding in external contour to the general peripheral shape of the hat-crown to be finished.

F is a rock-shaft journaled within brackets G, extending from said uprights. Rigidly secured to the rear end of said rock-shaft is an arm H, which extends immediately over the templet E and has a bearing directly thereon, so that it will be readily understood that as the templet revolves it will act as a cam to rock the shaft F. The forward end of this shaft terminates in box I, to which is swiveled one end of an arm J, the other end of said arm being free to rise and fall simultaneously with the arm H.

K K' are yokes formed at either end of the arm J, and within these yokes are journaled small drums L L', around which runs an endless belt M, adapted to carry the sand-paper N, which latter is applied on the belt in the usual manner. The short shaft of the drum L is extended and provided with a handle O, so that the belt may be fed along in order to occasionally present fresh sand-paper to the hat.

P is an ordinary hat-block over which the hat to be finished is placed. This block is secured upon the forward end of the shaft directly under the sand-belt by means of the usual chuck Q, or in any suitable manner.

R is an ordinary reverse right and left handed continuous screw on the power-shaft, and S is a lever pivoted at its rear end to a bracket T and provided with a shoe U, adapted to travel back and forth within the groove of said screw, whereby an oscillatory or swinging movement is imparted to the free end of said lever for the purpose presently explained.

V is an intermediate lever pivoted at one end to the post W and having its other end slotted to receive a pin a , projecting downward from the collar X, which latter is rigidly secured on the rock-shaft F.

The levers S and V are connected by a set-screw Y, which passes through elongated slots $b c$, formed in said levers, respectively. Thus it will be obvious that the motion imparted to the lever S by the travel of its shoe in the groove of the screw will be transmitted to the rock-shaft through the intermediate lever V, causing said shaft to move back and

forth longitudinally within its bearings. This movement causes the sand-paper belt to travel lengthwise over the hat during the rotations of the latter, so as to operate upon every part
 5 of the crown of said hat. It will also be seen that this longitudinal movement of the rock-shaft causes the arm H to travel lengthwise of the templet, and as the contour of said
 10 templet conforms to that of the hat-block upon which the hat is placed it follows that the sand-paper belt will be made to bear with uniform pressure throughout the area of the hat-crown at its varying widths during the rotation of the latter.

15 The swiveling of the belt-carrying arm to the rock-shaft permits the belt to adapt itself automatically to the surface of the hat, so as to always act on the same tangentially.

To vary the longitudinal reciprocation of
 20 the rock-shaft, it is only necessary to change the position of the set-screw Y in the slots *b c*. If at any time it should become desirable to reciprocate the sand-paper belt by hand, the set-screw may be removed from the slots, thus
 25 disconnecting the rock-shaft from the screw and leaving said shaft free to be moved back and forth by the manipulation of any suitable handle Z.

I claim--

30 1. In a hat-finishing lathe, the combination, with the hat-block and templet mounted on the power-shaft, of the sandpapering mechanism carried by a rock-shaft and means, as a system of levers connected to said power
 35 and rock shafts, whereby the latter is automatically operated, substantially as set forth.

2. In a hat-finishing lathe wherein the sandpapering mechanism is adapted to the contour of the hat-block by means of a templet
 40 and an intermediate rock-shaft carrying said mechanism and receiving motion from said templet, means actuated from the power-shaft of the machine for imparting to said rock-shaft a continuous forward-and-backward
 45 feed, whereby the sandpapering mechanism is automatically caused to travel lengthwise of the hat-crown, substantially as and for the purposes described.

3. In a hat-finishing lathe, the combination of the hat-block and templet, both secured on
 50 the power-shaft, the rock-shaft journaled in brackets extending from the frame of the machine, the lever secured to said rock-shaft and extending over and against said templet, the
 55 sandpapering mechanism, also secured to said rock-shaft in close proximity to the hat-block, a continuous reverse screw-thread on said power-shaft, a lever pivoted to the frame of the machine and having depending therefrom
 60 a shoe which extends within the groove of said screw, a secondary lever, also pivoted at one end to the frame of the machine, the other extremity being connected to the rock-shaft, and a binding-screw extending through said
 65 pivoted levers within elongated slots therein, substantially as shown and described.

In testimony whereof I affix my signature in presence of two witnesses.

CHARLES H. REID.

Witnesses:

J. HOWARD TAYLOR,
 NORMAN HODGE.